

# USER MANUAL

2020/21



PINE  
SAPINO

TIMBER / ALU  
TINIUM

MAHOGANY  
MOGANO

**STM**  
windows

- quality pays off

# CONTENTS

Congratulations on the purchase .....	3
Technical terms.....	4
Reception and storage .....	5
Handling and lifting .....	5
Installation and fastening .....	6
Adjustment and sealing .....	9
Delivery .....	13
Hot air blowers .....	13
Cleaning .....	13
Surface treatment .....	14
Maintenance/cleaning of Surface-treated products .....	14
Expected outcome of industrially Surface-treated timber elements.....	15
How to remove any resin .....	16
Weatherstrips .....	16
Oil treatment of mahogany .....	17
Installation of glazing unit .....	17
Weatherstrips .....	18
Replacement of glazing unit (timber/aluminium) .....	18
Side hung window .....	19
Top guided window .....	22
Top swing window.....	23
Tilt-turn (side-bottom hung) window/door .....	24
Entrance doors and stable doors .....	26
Terrace doors .....	27
Sliding doors .....	28
Airing the building.....	29
Avoid moisture damage .....	30
5-year warranty, Elements in pine, mahogany and oak .....	32
10-year warranty, Elements in timber/aluminium .....	33
The DVV label .....	34
The CE label .....	34
Notes .....	35

# CONGRATULATIONS

## ON THE PURCHASE OF YOUR NEW STM ELEMENTS

STM WINDOWS A/S has been producing high quality external windows and doors since 1972. The company is constantly developing and, today, has an extensive range of external quality doors and windows in pine heartwood, mahogany and timber/aluminium.

Everything is made to measure and produced individually using modern production methods and high-tech special purpose machinery.

On the following pages you will find a wide selection of installer information, product information and good advice and guidance.

It is our hope that with this Comprehensive Guide we will give you a helping hand with regard to carrying our general maintenance as well as how the elements function and are operated.

We hope that you are satisfied with and, with the right care, will enjoy the benefits of your elements for many years to come. Should there however be any aspect of the delivered elements that do not meet your expectations, please get in touch.

Contact your installer or builders merchant who will pass the message on to our Service department immediately.

*Read more about us at  
[www.stmvinduer.dk](http://www.stmvinduer.dk)*

*- quality pays off*

# TECHNICAL TERMS

To help you understand the technical terms used on the following pages we have endeavoured to clarify the various technical terms with reference to the drawings.

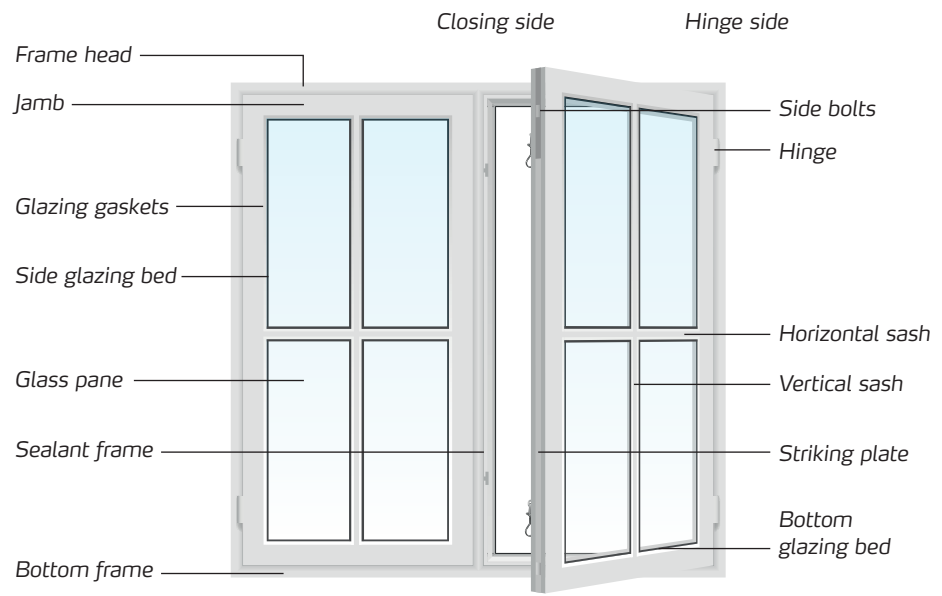

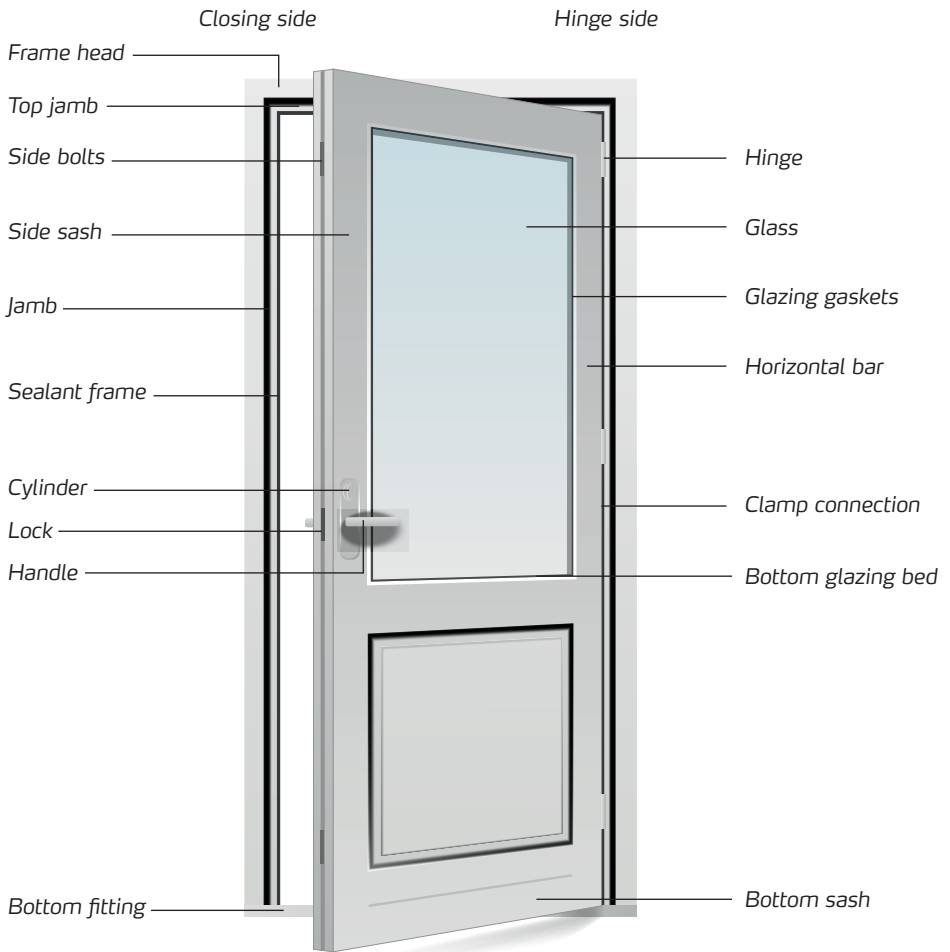

# RECEPTION AND STORAGE

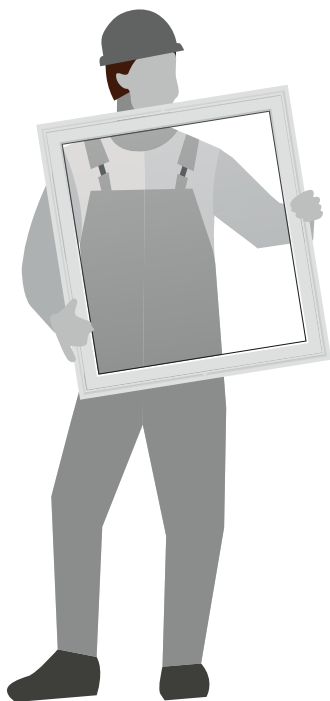

On receiving the elements, please check that they completely match the order confirmation and that the elements are fault-free.

Contact the dealer immediately if there are any faults, transportation damage or defects. Transportation damage must be noted on the consignment note in order for any claim to be valid. If there are visible faults, you must not commence installing the elements until a claim has been submitted.

The elements must be stored on an even surface and kept free of moisture\* and dirt. If the elements are stored outdoors, they must be protected against precipitation by means of a stable covering. Make sure there is adequate ventilation around the elements. If the covered elements are

stored for more than 4 months, this can result in problems with the glass and the timber.

## HANDLING AND LIFTING

Lifting can be carried out by means of various types of fork-lift truck, straps under the element, the use of a lifting bracket, a "runner", trolley etc.

It is generally recommended that elements are lifted in the vertical position and by the jambs.

However, elements weighing less than 30 kg can be lifted by the frame head. Elements must not be lifted by the sash bars. Doors with aluminium steps must not be moved using a Sack Truck unless there is a batten between the step and the barrow.



# INSTALLATION AND FASTENING

STM's products must not be statically stressed by other building elements and must not be used as load-bearing supports, including mullions and end corner endings.

Correct installation is crucial to the function and lifespan of the elements. Therefore, installation should be carried out by professional installers of windows and doors.

The following instructions cover some of the main points relating to the installation process, although not every detail, which you may find useful.

When installing the actual elements, for most element types it would be appropriate to remove the window/door frame during the first part of installation of the frame. If you have any doubts in relation to separating the frame and the sash, please contact STM Windows for further advice and guidance.

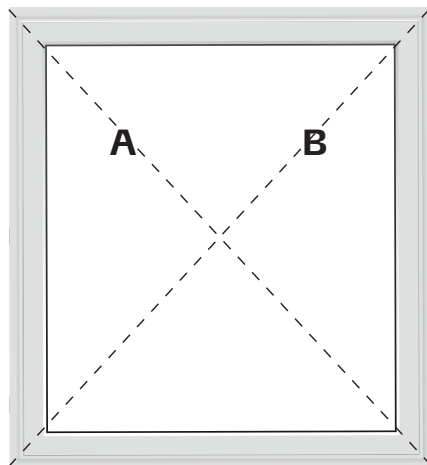

*Frames must be parallel.*

*Diagonal measures:  $A = B$*



### General points on installation

The frame is normally placed in the "aperture" with a uniform sealant gap between the sideframe and the frame head in consideration of the level of the sill in relation to the external sill/floor. The sealant gap between the frame and the surrounding masonry should be around 12 mm. The frame must be plumb on both the wide and the narrow side.

In addition, the frame must be adjusted and fastened to ensure the correct closing position and space between the sash and the frame.

It is recommended that the window/door element is placed with a recess of 4-5 cm from the external surface of the "masonry" to provide a degree of protection against the weather.

However, when mounting windows with top-swing fittings, consideration and clearance must be given to the movement of the sash.

### General points about fastening

Windows and external doors must always be secured to the surrounding building parts by "mechanical means" such as frame bolts/dowels or ironmongery.

These are normally placed in the frame rebate.

Timber/aluminium elements mounted in the frame rebate must always be mounted with flathead frame bolts/dowels.

Before facing is carried out, elements secured to the inner wall must, following construction, be wedged and secured to the facing to ensure the stability of the elements.

If the elements are to be secured later, the frame must be adjusted before they are secured in order to achieve the correct closing position and the prescribed space between the frame and the sash.

If any foaming material is used to fill the gap between the outer frame surface and the surrounding masonry, the element must still be secured to the surrounding building parts by mechanical means, for example, frame bolts/dowels or ironmongery.

The fixing of the frame is secured by means of mechanical means and permanent wedging. At the same time, there must always be permanent wedging under jambs, mullions and the aluminium sill.

*Securing to the surrounding building parts by ironmongery*

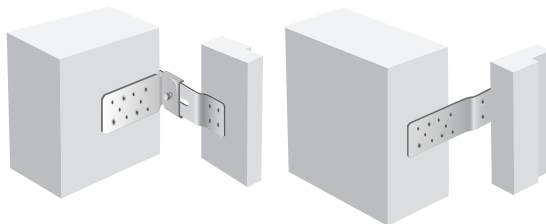

## Wedging

Wedging must be of a suitable size so that there is sufficient space for sealant material, both outside and inside the seal. The supporting surface must not measure less than 25 cm<sup>2</sup> and the material must be moisture-resistant, for example, waterproof plywood, oil-tempered Hard Board, synthetic material or asphalt.

## Securing and wedging:

The various main types of elements are wedged and secured as shown in the following sketches:

— : Permanent wedging.

⊥ : Fixing point for permanent wedging.

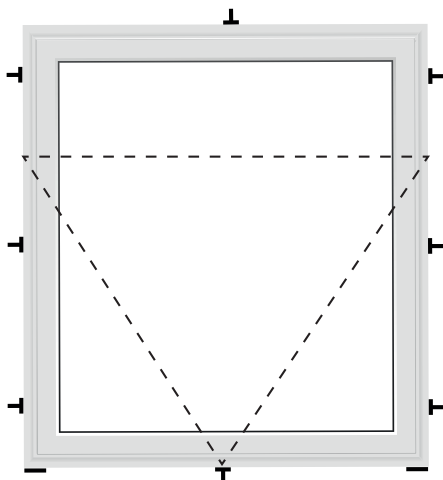

## Windows:

*Windows must have permanent wedging below the outer ends of the sill.*

*In the case of windows with mullions, there should also be permanent wedging under the sill.*

*In the case of elements with heights of less than 100 cm, the centre fixing in the jambs can be omitted. In the case of elements less than 100 cm wide, the fixing in the frame head and the frame sill can be omitted.*

*The distance between the two fixing points must be no more than 80 cm.*

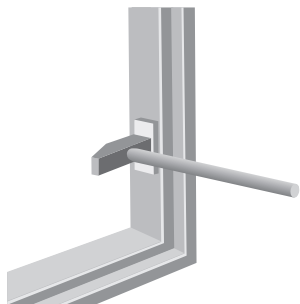

*Use a hammer and tapping block*

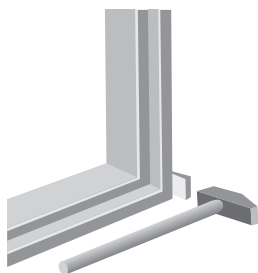

*Correct wedge position*

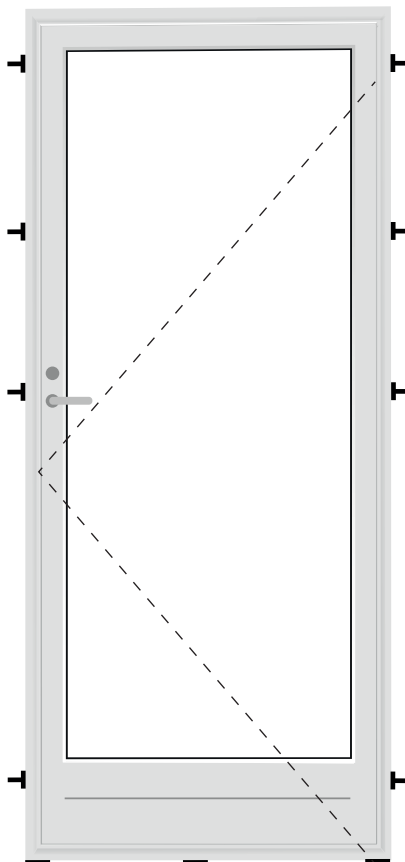

### **Single doors:**

*Single doors must have permanent wedging at the outer ends of the sill.*

*It is also recommended that the threshold is supported in the middle of the Walking line.*

*Doors with aluminium sills must have additional permanent wedging approximately every 25 cm.*

*The fixings on the hinge side are placed in the rebate, as close to the hinges as possible, since the entire weight of the door is centred here.*

*To protect against burglary, it is important that there is permanent wedging and fastening behind the striking plate.*

*The distance between the two fixing points must be no more than 80 cm.*

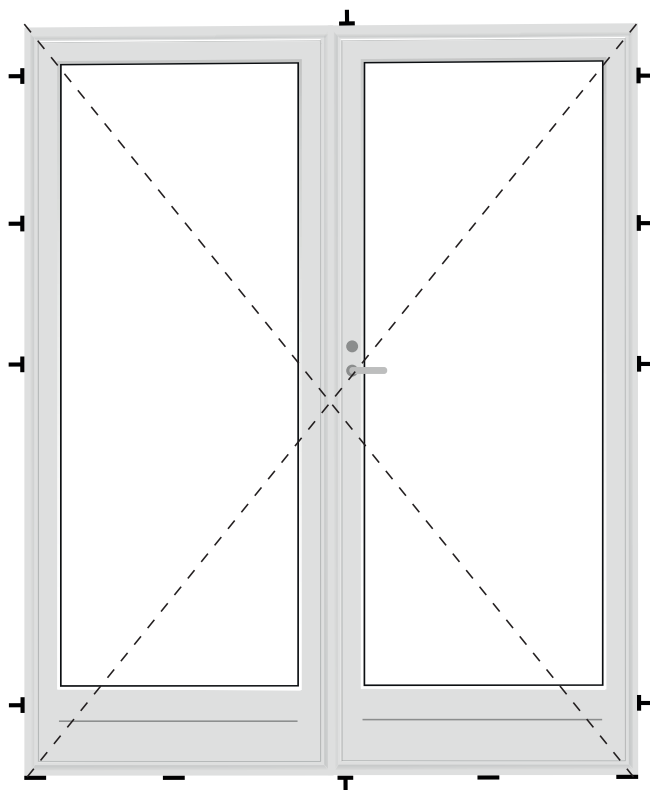
**Double doors and doors with side panel:**

Double doors must have permanent wedging at the outer ends of the sill and under the wing joint or mullion. It is also recommended that the threshold is supported in the middle of the walking line.

Doors with aluminium thresholds must also have additional permanent wedging approximately every 25 cm.

The fixings on the hinge side are placed in the rebate, as close to the hinges as possible, since the entire weight of the door is centred here.

The frame head and the frame sill in double doors are secured to the wing joint.

Doors with side panels are secured to the frame head and the frame sill at the mullion.

The distance between the two fixing points must be no more than 80 cm.

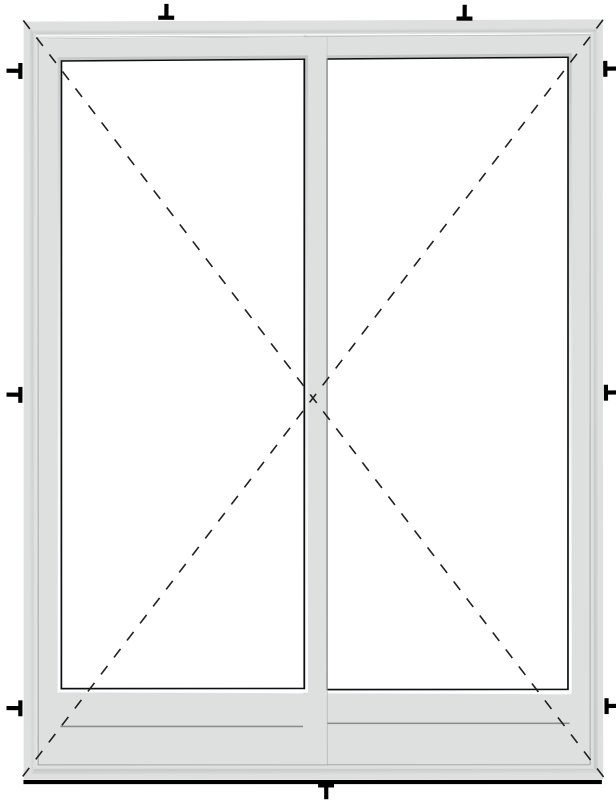

### **Sliding doors:**

*The sliding door must be wedged and secured every 80 cm on the jamb and the frame head. The sill must be wedged along its entire length.*

*Sliding doors are secured to the rebate at the door frame. It is important that the plastic wedge on the catch hits both striking plates at the same time.*

*The sliding door is secured to the rebate by means of a fixed part. The sliding door is secured to the rebate in the frame head and must not be included in a construction that is exposed to stress from overlying elements.*

*The sliding door is secured at the bottom in the aluminium sill.*

# SECURING, ADJUSTING AND SEALING

## SECURING OF TIMBER ELEMENTS

As far as possible, elements should be secured to the frame rebate, as close to the hinges as possible.

(Solution 1).

However, they can be secured to the internal frame part (Solution 2).

This only applies to fixed frame/ fixed sash elements.

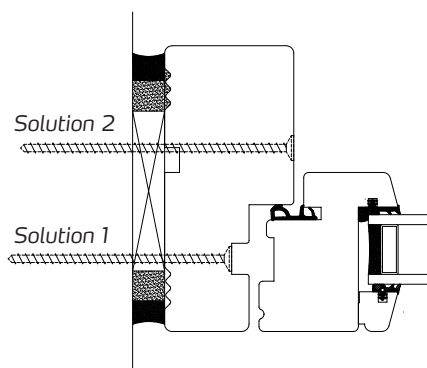

*Placement of screws*

# SECURING OF TIMBER/ ALUMINIUM ELEMENTS

These should be secured in composite parts, as close to the hinges as possible (Solution 1).

However, they can be secured to the internal frame part (Solution 2). This only applies to fixed frame/ fixed sash elements.

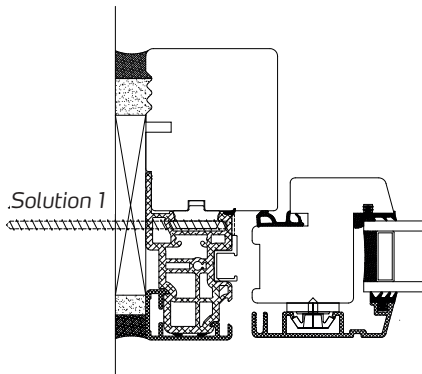

Placement of screws Tinium 2+ top guided and top swing windows.

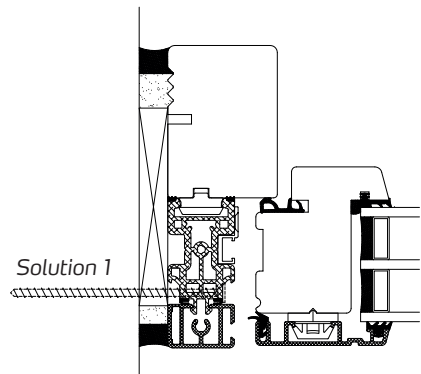

Placement of screws other Tinium 2+ elements.

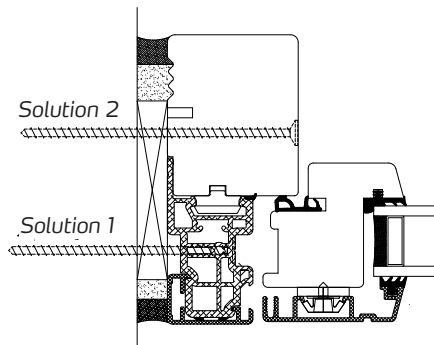

Placement of screws Tinium 2020 top guided and top swing windows.

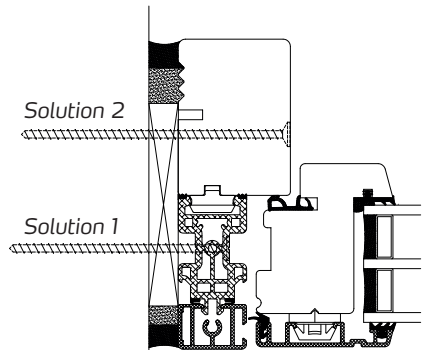

Placement of screws other Tinium 2020 elements.

## ADJUSTMENT AND SEALING

The sealant work must be done according with sealant manufacturers recommendations and current standards.

When stuffing the insulation material, it must not be compressed too hard as this will cause the frame parts to curve. If any foaming material is used for insulation purposes, the frame must be reinforced or secured in some other way to ensure that the straightness

of the frame is maintained until the foaming process is finished completely. Always finish off with a protective covering on the outside in the form of grout, sealant tape or another effective material.

The sealant industry's recognised sealant materials can be used with all our products.

Never use limestone/cement mortar for timber/aluminium elements.

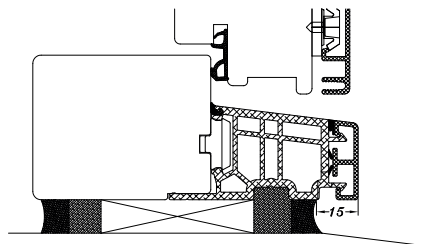

*Tinium 2+ Outward sloping sill*

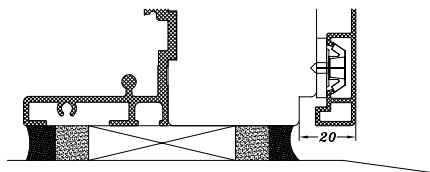

*Tinium 2 + Sliding/tilt door*

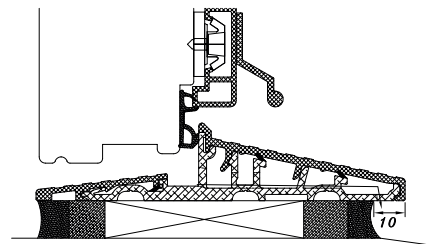

*Tinium 2+ Inward sloping aluminium sill*

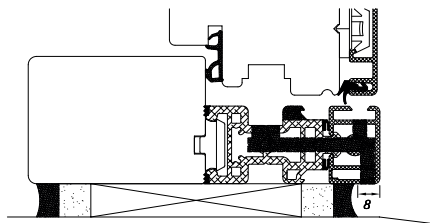

*Tinium 2020 Outward sloping sill*



## JOINING TIMBER ELEMENTS

In order to preserve the wood and keep heating consumption low, it is important that the sealing work stays intact. Therefore, the sealing work should be inspected once a year, and any leaks should be remedied using the same type of material as the existing material. In the case of major leaks, all of the sealing material should be replaced. In this situation, it must be assessed whether another type of sealant would be more suitable than the existing one.

When sealing inward-opening doors with an aluminium sill, sliding/tilt doors and timber/aluminium elements, the sealing on the frame sill should be pulled back (see illustration), so that the drainage apertures or not completely or partially blocked.

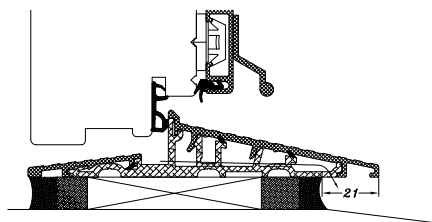

*Tinium 2020 Inward sloping aluminium sill*

The elements are joined side by side by fixing them at a number of points which at least correspond to the fixings on the sides. Supplementary wedging is provided under the joined up frames, and the frame head and sill are fixed near the joined elements.

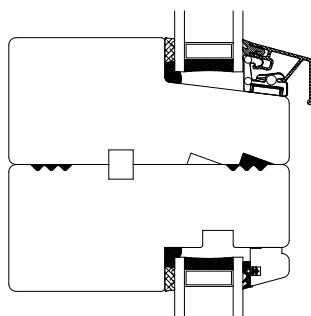

*Horizontal joint*

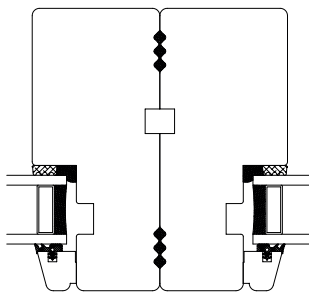

*Vertical joint*

## JOINING OF TIMBER/ ALUMINIUM ELEMENTS

The elements are joined at a distance of at least 11 mm. The elements are fixed at a number of points that as a minimum correspond to the fixings on

the sides. Supplementary wedging is provided under the joined up frames, and the frame head and sill are fixed near the joined elements.

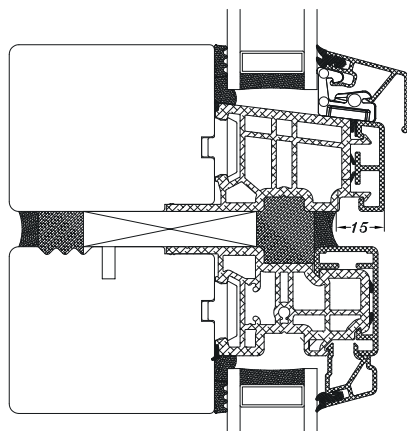

*Tinium 2+ horizontal joint*

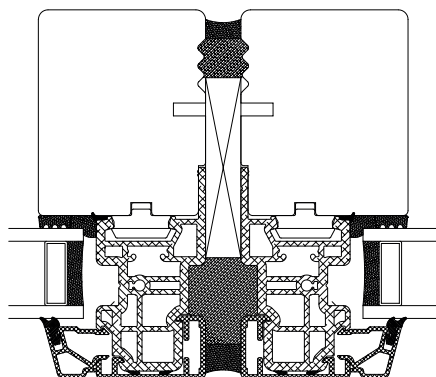

*Tinium 2+ vertical joint*

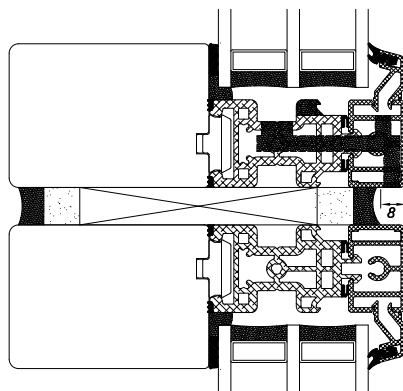

*Tinium 2020 horizontal joint*

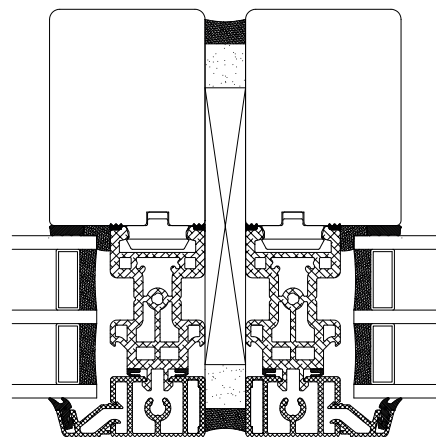

*Tinium 2020 vertical joint*

In the joining of outward-sloping timber/aluminium doors and side panels where the hinge side is to be joined to the side panel, a special composite screw is required, for example, RH13158 (5.0 x 60 mm).

However, the placement of the screws and the permanent support approximately every 25 cm should be as close to each side of the door hinges as possible.

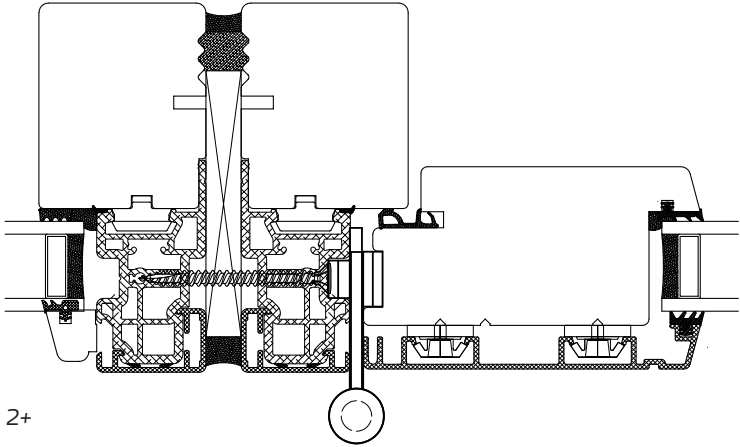

*Tinium 2+*

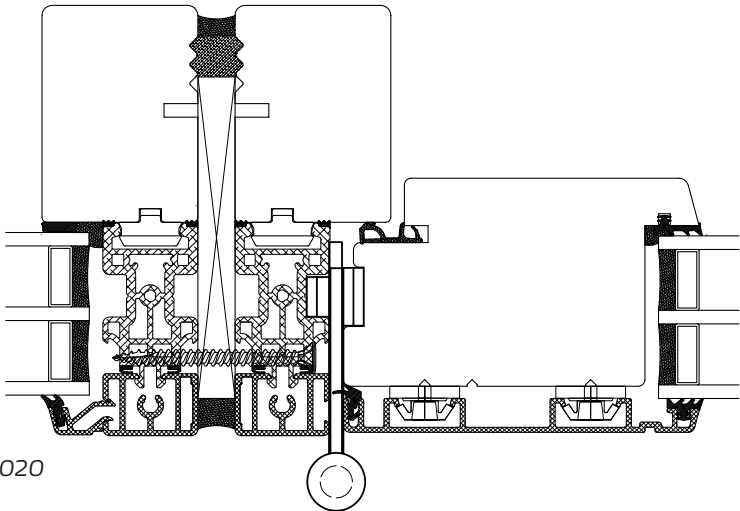

*Tinium 2020*

## DELIVERY

Prior to delivery to the developer, it is the responsibility of the person responsible for installation to check the following:

- that weatherstrips, ironmongery and rebates are cleaned of any mortar and other construction debris
- that opening sashes have been adjusted to have the correct clearance
- that hinges and closure clasps/ bolts have been adjusted to have the correct friction or are easily moveable
- that all moveable parts, with the exception of friction parts, are lubricated with a suitable lubricant
- that any damage to the surface treatment on elements with finished surface treatment is remedied
- that users are instructed in the proper operation of the elements.

## HEAT CANNON/ DEHUMIDIFIER

Any use of heat cannons/dehumidifier must be carried out in a controlled environment so that the moisture level in the timer does not fall below the prescribed 9%.

## CLEANING

### **Timber/aluminium:**

The aluminium frames and sashes are under constant stress from the environment in which the building is located. Areas with heavy traffic and industrial areas resulting in air pollution and coastal environments with a high salt content in the air result in greater soiling of facade elements and therefore need to be cleaned more frequently.

It is recommended that they are cleaned at regular intervals, 2-3 times a year.

Frames and sashes can be washed with ordinary water, if necessary with a neutral cleaning agent added, after which the surfaces and sides are wiped dry.

### **Timber:**

Industrially-lacquered surfaces are under constant stress from the environment in which the building is located. Areas with heavy traffic and industrial areas resulting in air pollution and

coastal environments with a high salt content in the air result in greater soiling of facade elements and therefore need to be cleaned more frequently.

It is recommended that they are cleaned at regular intervals, 2-3 times a year.

Frames and sashes can be washed with ordinary water, if necessary with a neutral cleaning agent added, after which the surfaces and sides are wiped dry.

### **Pine**

Pine is delivered exclusively in the form of hand-cut, glued laminate, which is extremely strong and resistant and has no knot penetration in the coating. The Association of Danish Window Manufacturers' basic treatment "2 ØKO" has been added to the pine heartwood in accordance with Danish Window Verification's (DVV) instructions.

The timber is then sanded down and the surface treated with a water-based coating using electrostatic equipment.

Read more about the "Expected outcome of industrially surface treated timber elements" (The Association of Danish Window Manufacturers' Technical Regulations).

# SURFACE TREATMENT

## **Mahogany**

In the case of hardwood, timber with a density of at least 550 kg/m<sup>2</sup> is used, in accordance with DVV instructions.

The surface treatment of hardwood comprises of treatment with oil.

## **Timber/aluminium**

Pine is delivered exclusively in the form of hand-cut, glued laminate, which is extremely strong and resistant and has no knot penetration in the coating.

The Danish Window Industry's basic treatment "2 ØKO" has been added to the pine heartwood in accordance with Danish Window Verification's (DVV) instructions.

The timber is then sanded down and the surface treated with a water-based coating using electrostatic equipment.

Read more about the "Expected outcome of industrially surface treated timber elements" (The Association of Danish Window Manufacturers' Technical Regulations) on page 13.

Our aluminium profiles undergo a 9-step chroming process followed by lacquering in accordance with DIN50.939.

In the case of hardwood, timber with a density of at least 550 kg/m<sup>2</sup> is used, in accordance with DVV instructions. Oil treatment is used for treating hardwood surfaces.

## **MAINTENANCE/ CLEANING OF SURFACE-TREATED ELEMENTS**

The durability of the surface treatment of the elements depends on how exposed they are to the sun, wind and water. Therefore, you need to inspect and, if necessary, maintain your elements regularly. The interval at which you do so varies from a few months to many years.



The timber must always be maintained when it is no longer water-resistant in order for the surface to retain an intact protection. If any holes appear in the surface treatment, the moisture can penetrate the timber and the timber will start to decay. In addition, the elements should be cleaned externally with water, with car shampoo added, if necessary, in conjunction with general window cleaning.

### **Renovation of the surface treatment:**

1. Remove any loose paint
2. Remove any loose resin with alcohol and rinse with water
3. Wash off with water with ammonia or a basic cleaning agent
4. Exposed timber is primed with a clear oil-based wood protection
5. Water/alkyd paint is maintained.

Expected outcome of industrially surface-treated timber elements  
Companies affiliated to DVV carry out the surface treatment of timber elements which, as a minimum, provide the following outcomes: (Terminology according to the Danish Professional Painting Treatment Directory (MBK), issued by the Danish Technological Institute).  
All surfaces are treated, but the thickness of the coatings cannot be expected to be uniform all over.

	Expected result	Function class*	Comments
Visible surfaces of closed element	DLG **	III	Mean value of coating thickness > 60 µm (80 µm)
Visible surfaces of open element	DG **	III	The surface must be non-absorbent
Non-visible surfaces (against wall)			No requirements

References:	Examples:
*Function class III	Parts of buildings facing south or west, affected by varying levels of humidity or traffic pollution or other harsh impacts.  See also supplementary description of outcome.
**Covered, closed, and smooth surfaces (DLG)  	Surfaces, edges and rebates are of a uniform colour and gloss and feel smooth to the touch. Pores are closed. Holes, cracks and joints are closed and filled out. Rough spots originating from the base may occur. Hardwood is exempted from the requirement for filled-out surfaces.
*** Covered and smooth surfaces (DG)  	Surfaces, edges and rebates are of a uniform colour and gloss and feel smooth to the touch. Rough spots, open pores, holes, cracks and joints originating from the base may occur.

## Supplementary description of outcome

Generally, it must be accepted that timber is a natural material and therefore, often very inhomogeneous. Therefore, there will be variations in structure and gloss, star shakes and other variations are normal, for example, irregularities around knots where partial peeling, blistering and the formation of wrinkles may occur. On light colour finishes, discolouration from knots may occur. Knots can be plugged or filled with a suitable filler but they will always remain visible. Similar colour variations in the form of yellow lines/surfaces may occur.

Another irregularity in the surface treatment may be lumps of resin. The lumps can be distributed randomly or follow the grain of the wood.

The resin can also penetrate the coating and form small droplets on the surface. Once the droplets have been on the surface for a while and have crystallised, they can be removed by light brushing or scraping, without causing damage to the surface treatment.

Timber elements with a high resin content may occur. In these cases, larger quantities of resin may seep through.

Production is carried out industrially, which provides certain benefits, for example, a high, uniform quality and treatment of all surfaces.

Unless it has been agreed otherwise, it should be expected that glazing beads have been mounted using a nail gun, which results in the surface treatment being penetrated.

The durability of the surface treatment of bottom glazing beads made from timber cannot be expected to correspond to the durability of the other surfaces.

In the case of south-facing facades that are particularly exposed to strong sunlight and sea air, or where the moisture from inside the building has a particular impact, maintenance intervals should be adapted accordingly.

For maintenance, refer also to the Danish Professional Painting Treatment Directory (MBK) or the manufacturer's instructions.

This version was revised on 15 November 2012.



## HOW TO REMOVE RESIN

If there is a large amount of resin, the best way to remove it is to wait until the resin has solidified (crystallised).

Using a knife, scraper or similar instrument, you can scrape it away carefully (although not all the way down as this may damage the coating). The remaining resin can now be removed with household alcohol. The alcohol can be brushed on to the surface. Leave it to work for a couple of minutes and then dab it carefully with a cloth or cotton wool. The same procedure is used for any brown blotches.

It is important that you do not rub it with a hard material as the coating is at risk of being damaged - and remember to wash it down with clean water after treating it with alcohol.

The type of coating we have chosen to use for surface protection, more often than not, allows the resin to penetrate through the coating without causing any scaling. This means that once the resin is removed, the surface is intact once more and requires no further treatment.

In these cases, you will achieve an attractive and durable surface treatment if, a couple of times a year, you wipe down the windows and doors with a cloth moistened with household alcohol.

The alcohol works on the coated surface, therefore, to finish off you should remove any remaining alcohol using a damp cloth (water).

As we said, we know that resin can be annoying, but we hope that you will make use of the above advice and enjoy the products for many years to come. It is important to remember that resin in wood is a sign of good health and gives it a longer lifespan.

## WEATHERSTRIPS

Weatherstrips should be lubricated regularly with silicone in order to retain their elasticity and thus a functional seal. At the same time, it prevents the weatherstrips from freezing during the winter months.

### Coastal areas

In coastal areas, with a high concentration of salt in the air, there is an increased risk of corrosion on all metal components. In this case, more frequent cleaning and maintenance is required, i.e. rinsing of all surfaces and lubrication of moving parts a bit more often than normal. In the case of metal and plastic surfaces, it may be advantageous to use the same cleaning agents as you would use on the lacquer of a car.

## OIL-TREATMENT OF MAHOGANY ORE OAK

The delivered products are treated with an oil-based product in the factory. After installation products have to be treated with an oil-based product again.

At regular intervals, and a minimum of once or twice a year, it should be checked whether the surface is still protected, especially where south and west facing sides are exposed.

For the maintenance of the products, we recommend TRÆ-NOLIN 35 Wood Oil transparent or tinted from TRÆ-NORD. All maintenance is carried out by treating the wood once with TRÆNOLIN 35 wood oil.

On smooth wood, any surplus oil is wiped away using a dry cloth. It is recommended that the elements are given a finishing treatment within the first 3 months after they have been installed. The wood should then be retreated as and when required.

These maintenance intervals are for guidance only since the durability of the treatment depends on how exposed the elements are to sun and wind. Therefore, maintenance should be carried out when the wood is no longer waterproof.

The wood should be dry and free of dirt and grease before commencing treatment.

Application and the application methods are described on the product.

### TRÆ-NOLIN

can be purchased from: STM Windows  
Email: [sale@stmwindow.com](mailto:sale@stmwindow.com)

## INSTALLATION OF GLAZING UNITS

The installation of double-glazing units, including their replacement or where the glazing units have not been installed in the elements in the factory, is carried out in accordance with The Glass industry.

The installation instruction can be obtained from the Glass industry's webpage: [www.glasindustrien.org](http://www.glasindustrien.org).

The glazing gasket between the glass and the wood is constructed with an EPDM rubber seal on both the outside and the inside.

The glazing gasket requires no actual maintenance, but it is recommended that it is inspected once a year.

If the rubber seals are worn out or where there is extensive leakage, they should be replaced. The glazing bed is dismantled and the glass and rebate cleansed of any old sealant material, after which the new bead is inserted. It is recommended that new glazing beds are installed at the same time.

# Installation of glazing unit

## WEATHERSTRIPS

All elements are fitted with hard-wearing and weather-resistant weatherstrips.

The weatherstrips are cut at an angle in the corners and secured in a groove. Weatherstrips must not be painted over or brushed with wood protection agent. If necessary, this can be prevented by covering the weatherstrips with masking tape, which should not be removed until the surface treatment is completely dry.

They should be cleaned using an ordinary household cleaning agent, such as Ajax.



## REPLACEMENT OF GLAZING UNIT (TIMBER/ALUMINIUM)

### Outward opening windows and doors - timber/aluminium

1. Remove the vertical bars, by sliding the spatula below the bar
2. Remove the Horizontal bars, by sliding the spatula below the bar
3. Dismount the alusash by turning the clips 90 degrees using the special key
4. Release the glass/panel by cutting the silicone seal free
5. Dismount the clips on the sashes and take the glass/panel out
6. Clean any old silicone from the glass rebate (if necessary, replace defective sealing strip)
7. Sealing of the corners with silicone (protection against burglary)
8. Insert glazing unit
9. Replace any broken plastic clips on the outer frame
10. Click the aluminium cap on
11. Mount the plastic clips on the sashes.
12. Mount horizontal sashes
13. Mount vertical sashes.

If necessary, see illustration on page 4. The replacement of glazing units should always be carried out by professional tradesmen.

### Fixed sash timber/ aluminium

1. Dismount clamp
2. Dismount vertical glazing beads
3. Dismount horizontal glazing beads.

# Operation and function

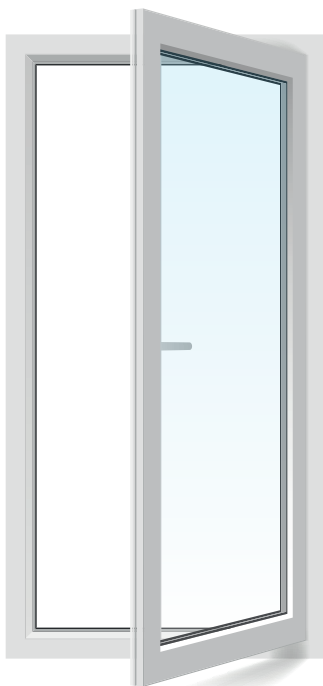

## SIDE HUNG WINDOW

### Operation, standard

The standard version of our side-hung window is supplied with a standard espagnolette and storm catch.

These can, by special agreement, be supplied with a safety device. This safety device works by blocking the arm of the catch at the console.

The window is secured in the open position by a storm catch on the hinge side.

Multi-leaf windows can, by special

agreement, be supplied with a “rescue mullion” (loose central mullion) in order to meet the requirements for the window to be opened by firemen in an emergency. In this case, the mullion is fixed to one of the sashes and thus follows suit when the sash is opened. This loose mullion is released by releasing the release catches at the top and bottom of the mullion.

### Operating the handle

Our side hung windows can also be

*Espagnolette*



*Storm catch  
closed window*



supplied with an espagnolette bolt and friction brake. The window is operated by means of a single handle which operates both the closing mechanism and the friction brake. The friction brake is mounted at the bottom, which makes it possible to secure the sash in a random ventilation position from approximately 5 cm to almost fully open. The brake is activated by turning the handle to the closed position while the window is open. However, this does not apply to elements with loose

IPA brakes since this only functions as a friction brake. In strong winds, the brake is not able to lock the sash in the step-less ventilation position, nor in the open position.

Never close the window with the handle in the lock position.

Windows with handle closing are supplied with a striking plate so that the window can be secured in the ventilation position.

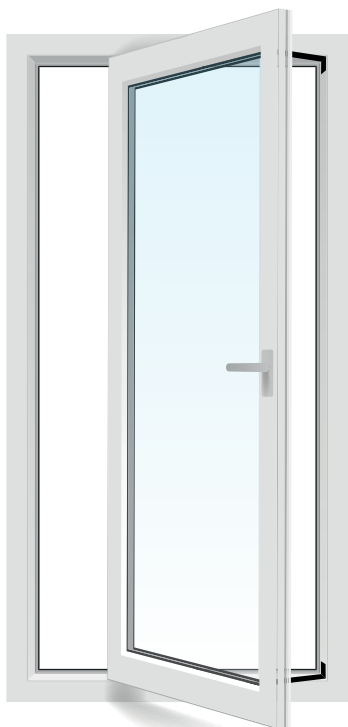

### **Sashes with “cleaning stays”**

Sashes with “cleaning stays” have the advantage that they allow you to clean the outside of the windows from the inside.

The hinges are concealed in the rebate, or visibly fitted on the outside of the sash.

With some types, the sash can be opened up to 90 degrees. At the same time, the window slides towards the handle side whereby a gap appears on the hinge side, just big enough to allow you to clean the outside of the glass.

With other types, the sash can be turned 180 degrees. This function is only designed for window cleaning and should not be used for ventilation and airing purposes.

### **Separation of the frame and sash**

Standard side hung sashes can be lifted from the frame when the sash is opened approximately 90 degrees and free of the sash rebate.

In the case of sashes with handle opening, the friction brake should be



released until the sash can be lifted out. This is done by turning the screws securing the arm of the friction brake on the frame.

Sashes with cleaning stays can only be separated by removing the screws in the sash. Separation normally requires 2 people.

### **Adjustment**

The catches can be tightened or loosened by turning the eyelet on the sash with a screwdriver.

“Cleaning stays” and friction brakes which are activated by the handle normally do not require adjustment. IPA friction brakes can be adjusted by turning the screw in the glider that is able to run backwards and forwards in the gliding track. The adjustment of hinges requires professional experience and knowledge.



### **Lubrication**

Hinges, handles, bar locks (handles) and rivet connections in the moveable parts, are lubricated at least once a year or as required using acid-free oil. In the case of sashes with friction brakes and/or concealed “cleaning stays”, it is important that the gliding track is kept free of oil and dirt. In addition, they must not be painted over.

### **General**

Never open a side hung window for ventilation unless it is secured by a restrictor or friction brake. In strong winds, the brake is not able to lock the sash in the step-less ventilation position, nor in the open position.

### **Separation of the frame and sash**

The sash can only be separated from the frame when it is in the horizontal position. The sash is then lifted free of the hinges.



## TOP GUIDED WINDOW

### Operation

Top guided windows are opened and closed using the handle in the centre of the bottom sash. At the very bottom there is a handle that is secured to the striking plate on the frame. The striking plate has two apertures, the innermost aperture is for opening the window, while the outermost is for the ventilation position.

When the window is opened and pushed out from the bottom, the win

dow sash glides down from the top at the same time.

This position is particularly useful and effective for ventilation purposes. However, it cannot be expected that the window will remain open in the stepless ventilation position during strong winds or draughts.

### Separation of the frame and sash

The sash can only be separated from the frame when the screws that are





securing the moveable arms to the sash are removed.

The screws can be removed when the window is open approximately 75 degrees. Separating the sash from the frame usually requires a minimum of 2 people.

### **Lubrication**

The rivet connection on the hinge fitting, the handle and the espagnolette are lubricated at least once a year or as required using acid-free oil.

The gliding track must not be lubricated, but kept free of dirt and paint.

### **Adjustment**

The adjustment of the espagnolette requires professional experience and knowledge.

The friction in the fitting is adjusted by turning the screw in the slide block on either side. It is extremely important that the friction screw is tightened equally on both sides since otherwise the sash may be uneven.

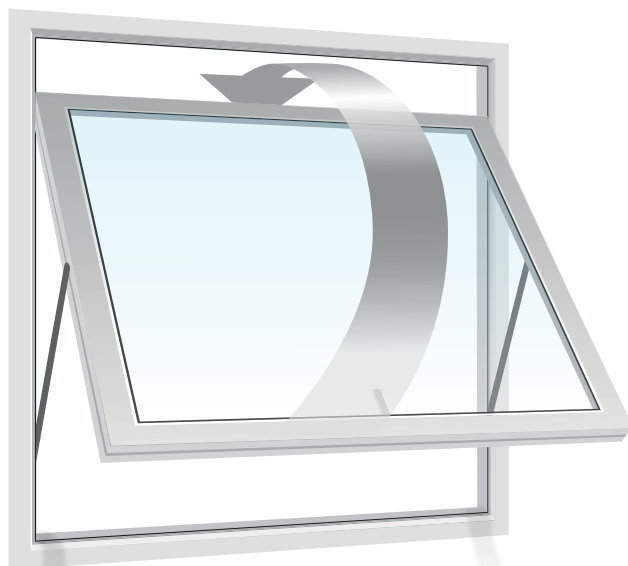

## TOP SWING WINDOW

With a top swing fitting, the window sash can be pushed out and turned all the way around outside the frame. Thus, the outside of the glass can be cleaned from the inside.

The sash is operated by means of a handle at the centre of the bottom sash, and by opening it 1-2 cm, the sash can be locked in the ventilation position. The top swing window is often fitted with a child-proof lock, which prevents the sash from being opened more than approximately 10 cm.

When the sash is turned all the way round, it is locked in the cleaning position.

The sash can also be opened to a random angle, but it should be noted that the position of the sash cannot be secured during strong winds or other impacts.

Be careful that the window is not installed in such a way that the sash can hit against the masonry at the top when the sash is turned all the way round.

When the window is opened and



pushed out from the bottom, the window sash glides down from the top at the same time. This position is particularly useful and effective for ventilation purposes. However, it cannot be expected that the window will remain open in the step-less ventilation position during strong winds or draughts.

### **Separation of the frame and sash**

The sash can only be separated from the frame when the screws that are securing the moveable arms to the sash are removed. The screws can be removed when the window is open in

the horizontal position. Separating the sash from the frame usually requires a minimum of 2 people.

### **Lubrication**

The rivet connection on the hinge fitting, the handle and the handle grip are lubricated at least once a year or as required using acid-free oil.

The gliding track must not be lubricated, but kept free of dirt and paint.

### **Adjustment**

This type of adjustment requires professional experience and knowledge.



## TILT-TURN (SIDE-BOTTOM HUNG) WINDOW/DOOR

### Operation

Tilt-turn windows/doors have several functions and can have closing points all the way round, depending on their size, but are nevertheless operated by means of a single handle.

The sash opens inwards, both in the side hung and the bottom hung versions.

### Closed position

In the closed position the handle should be turned downwards.

### Side hung function

The handle is turned to the horizontal position and the sash can be opened in the side hung position. In the side hung position, the handle must not be

turned up to the vertical position as the sash will hang incorrectly in the fitting. If this should happen anyway, turn the handle to the horizontal position while pressing the sash in at the top.

If the side hung function is used for ventilation, the sash should be secured against blowing inwards.

### Bottom hung function

The handle is turned up into the vertical position, whereby the sash can be opened approximately 10 cm.

### Separation of the frame and sash

Separation of the frame and sash requires professional experience and knowledge. Separating the sash from



the frame usually requires a minimum of 2 people.

### **Lubrication**

The lowermost hinge must not be lubricated since lubricating agent has already been applied to it.

All other moveable parts, for example, joints, rollers and slots should be lubricated at least once a year, or as required, using acid-free oil.

### **Adjustment**

Adjustment normally requires professional experience and knowledge. The position of the sash in the frame can be adjusted in all directions. The stopper on the lowermost bottom

hinge on the closing side is removed, after which the height can be adjusted using an Allen key.

Sideways adjustment is by means of the hinges on the closing side, using an Allen key/face wrench. The sash should be in the unlocked position while the adjustment is made.

The pressure of the sash on the weatherstrips can be adjusted by adjusting the striking plates in the frame rebate.

### **General**

Tilt-turn windows can be supplied with a special fitting so that the bottom hung ventilation position can be adjusted to several smaller openings.



## ENTRANCE DOORS AND STABLE DOORS

### Operation

As standard, entrance doors are supplied with a cylinder lock for oval cylinders and a 3-point espagnolette lock.

The lowermost and uppermost points are only engaged when the handle is lifted upwards. Likewise, it can only be locked with a key when the handle has been lifted upwards.

When the handle is pushed down, all 3 locking points are released.

### Operation of stable doors

The two parts of the stable door can be opened as a single door when the handle on the lower door is turned to the opening position, before the handle on the upper door is operated.

The door can only be locked with a key when the handle on the upper door has been lifted upward. It can be supplied with a one-point lock.

### Separation of the frame and sash

The sash can be lifted from the frame when the sash is opened approximately 90 degrees and free of the sash rebate.

### Lubrication

Hinges, locks and espagnolettes must be lubricated at least once a year, or as required, using acid-free oil.

### Adjustment

Adjustment requires professional experience and knowledge.



## PATIO DOORS

### Operation

As standard, terrace doors are supplied with a 3-point terrace door espagnolette lock whereby the handle operates the 3 closing points and, possibly, a friction brake on the upper edge of the door. The friction brake comes as standard.

The door can be opened when the handle is turned to the horizontal position.

Terrace doors with a friction brake can be locked in a random ventilation position with an opening ranging from approximately 5 cm to almost the fully opened position by turning the handle

to the closed position (downward).

However, it cannot be expected that the friction brake will keep the door in position in strong winds.

2-leaf terrace doors only have one handle on the moveable leaf, which opens first.

In the closed position, the other leaf is secured by 2 side catch bolts, one on top and one on the bottom.

### Separation of the frame and sash

The sash can be lifted from the frame when the sash is opened approximately 90 degrees and free of the sash rebate.



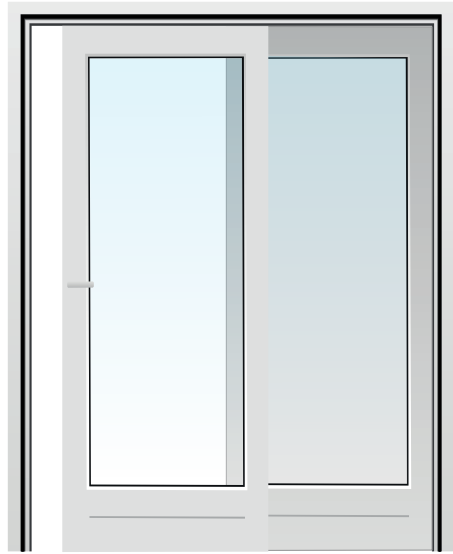

## SLIDING DOORS

### Lubrication

Hinges, locks and espagnolettes must be lubricated at least once a year, or as required, using acid-free oil.

### Adjustment

Adjustment of patio doors and sliding doors requires professional experience and knowledge.

### General

As an optional extra, the door can be supplied with a child-proof lock, key locking or a handle on both sides.

### Operation

A sliding door comprises a fixed section and a moveable section. By turning the door handle, the door sash is released from the frame. The sash can then be slid past the fixed section.

When opening and closing the sliding door, it must be ensured that the door handle is completely back in the locked position (vertical position).

### Lubrication

The track on which the door runs must be kept free of dirt and debris as otherwise it will collect on the wheels and ruin them. The moveable parts should be lubricated at least once a year, or as required, using acid-free oil.

# Airing the building

New windows will normally be extremely airtight, so therefore a more systematic approach to airing the building is needed than is the case with older, draughty windows.

During the construction period, ventilation is required to such an extent that condensation is not formed on the window panes.

If, during the day and in the evening, the outdoor temperature is 0 degrees, and dew is formed on the inside of the double-glazed window in an ordinary sitting room, the air in the building is too humid.

In these cases, ventilation is required to such an extent that dew is not formed on the window panes.

## **Therefore, bear the following in mind:**

- New windows are considerably more airtight than old windows. Therefore, there is a greater need for ventilation following the replacement of a window than there previously was.
- Newly built houses require more airing than older houses.
- The drying-out phase can often extend to more than a year.

This also applies to renovations and extensions.

- An adult human – or a medium-sized dog – releases approximately 2 litres of water a day.
- Problems with humidity increase when the temperature in the room is reduced and disappear when it is raised. Even a short-term reduction in the temperature at night time can result in condensation on the window panes.
- It is a balancing act to find the optimal point for saving energy and minimising humidity problems.
- Heavy curtains and broad window boards can make the air at the glass stagnate, causing cold and moist air to form condensation on the glass.
- On days with calm weather, the sun will supply more free heat than the heat that disappears during normal ventilation.
- Inadequate ventilation results in a poor indoor climate. This can result in coughs, headaches, stinging eyes, rashes and respiratory allergies.

## **AVOID MOISTURE DAMAGE**

### **– open the window!**

The air in a building can quickly become too moist due to, for example, cooking, bathing and watering pot plants. The moist air can be the cause of damp damage (mould spots) and health hazards (house dust mites).

Many people believe that a building “breathes on its own”, but this is seldom the case. Therefore, those dwelling in the house must ensure that there is sufficient ventilation to remove the moisture that arises in a building.

In newer properties, there is normally a mechanical ventilation system which removes the air from the kitchen and the bathroom through extraction vents in or near the ceiling. These must be open and kept clean in order to work effectively. Often, there are outdoor air ventilators in or near windows. This is where the air that is subsequently extracted through the kitchen and the bathroom comes from. These ventilators should always be kept open.

In older properties with “fanlights” - small ventilation windows - it may be necessary to always have them ajar to get enough fresh air.

**REMEMBER: VENITLATE THE ROOM SUFFICIENTLY TO PREVENT CONDENSATION ON THE WINDOWS.**

Even if you have to save on heating costs, the keenness to save money shouldn't result in moist room air and poor air quality. Fortunately, the cost of heating reasonable amounts of fresh air doesn't cost a fortune.

Fewer damp problems will arise if all rooms are more or less uniformly heated.

In newly constructed buildings, there may be construction moisture. Therefore, pay particular attention to ventilating such buildings during the first year after moving in.

The replacement of windows or the installation of weatherstrips on doors or windows can make a building so airtight that it requires more ventilation than it did previously.

Especially where there are smokers, it is a good idea to always keep outdoor air ventilators open or to leave “fanlights” ajar.

Contact the caretaker or inspector immediately if problems with dampness arise. It is easiest to remedy faults if you take action immediately.

**REMEMBER: A GOOD INDOOR CLIMATE REQUIRES GOOD VENTILATION.**

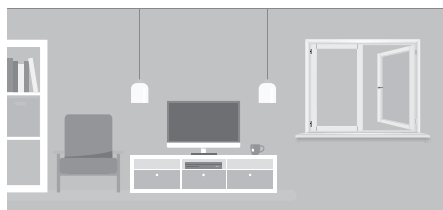

### In the living room

Air the room a couple of times a day or use outdoor air ventilators, if there are any. If condensation starts to form on the window panes, make sure the room is aired more. Don't turn the heating off completely in rooms that are not being used. Don't place cupboards or large pieces of furniture right up against an external wall - the air in the room must be able to circulate behind it, otherwise mould spots will appear on the wall.



### In the kitchen

Never block or close ventilation openings or extraction fans. Open up extraction fans fully or let kitchen ventilators or cooking hoods run on full power while cooking. Put the lid on saucepans during cooking, so that there will be less moisture in the air during cooking. Ventilate the kitchen well during and after cooking.



### In the bedroom

Ventilate the room and make sure that the bedclothes are aired every morning. Turn mattresses every now and then. Do not leave the bedroom completely unheated. If condensation forms on the window panes, make sure there is better ventilation to outside or the other rooms in the house.



### In the bathroom

Never block or close ventilation openings or extraction fans. As far as possible, avoid doing laundry, and especially drying clothes, in the building. However, if it cannot be avoided, use the bathroom and make sure there is good ventilation. Ventilate the bathroom well after bathing. The discharge of warm and moist air from the tumble dryer should be released directly into the open air.

# 5-year warranty

## ON SAPINO & MOGANO WINDOWS AND EXTERNAL DOORS



**Warranty and support: STM provides a 5-year warranty on timber products. We provide advice on re-treatment and guarantee delivery of spare parts for our products.**

### WINDOWS & DOORS IN TIMBER

- 1.1** This warranty is provided by the member of the Association of Danish Window Manufacturers below, hereinafter referred to as the warranty provider. In no way does it restrict or change the rights bestowed upon you under the agreement and/or legislation in relation to your supplier/contractor or in relation to the warranty provider.
- 1.2.** If, within a period of 5 years from the warranty provider's date of delivery, you have any claims in respect of manufacturing and/or material faults, this warranty guarantees your rights in relation to the warranty provider, as outlined in 1.3. The date of manufacture appears on the product label. If necessary, it is your responsibility to document the time of delivery.
- 1.3** If there is a valid claim in respect of manufacturing and/or material faults within the period stated in section 1.2, the warranty provider undertakes to deliver a new product free of charge.

However, under this warranty, the warranty provider does not cover any costs for dismantling of the old product and installation of the new product. Likewise, any consequential damage related to the replacement of products is not covered by this warranty. If, at the time of the claim, the product in question is no longer in production, the warranty provider is entitled to deliver another equivalent product instead. If the manufacturing/material fault can be adequately remedied by means of repair/partial replacement, the warranty provider can choose this solution instead. In this case, the repair/partial replacement will be carried out at no cost.

- 1.4** This warranty does not cover manufacturing and/or material faults in double-glazing units. However, in these cases, the double glazing manufacturer's warranty, to which reference is made, is applicable.
- 1.5** This warranty does not bestow any rights on you other than those outlined in section 1.3.
- 1.6** If you wish to make a claim in respect of manufacturing/material faults, the claim must be made within a reasonable time of the fault being discovered or the time at which it should have been discovered. The claim can be lodged with the warranty provider or with the contractor/supplier who delivered the product.
- 1.7** This warranty cannot be invoked if the alleged manufacturing/material fault is due to incorrect installation, non-existent or inadequate maintenance or incorrect operation. Reference should be made to the warranty provider's installation, operating and maintenance instructions.

With regard to surface treated timber windows/doors from the factory, your attention is particularly drawn to the maintenance guide and the description "Expected outcome of industrially surface-treated timber elements" (Appendix 14 in The Association of Danish Window Manufacturers' Technical Regulations). If, exceptionally, you have not received a maintenance/operation guide with your delivery, this can be obtained from the warranty provider.

- 1.8** Under this warranty, it is not possible to lodge a claim in respect of manufacturing/material faults that are due to conditions that occurred after the product has been delivered by the warranty provider. Claims lodged with the warranty provider in respect of faults that can, for example, be attributed to incorrect storage, transportation or installation by a middleman/contractor cannot be invoked with reference with to this warranty.
- 1.9** This warranty only applies to products which are physically located in UK when the warranty is invoked.

### We would like to point out that the warranty does not cover:

- 1.10** Damage and operational problems due to non-existent lubrication and maintenance and washing of the element's external powder-lacquered surface.
- 1.11** Damage and operational problems occurring on elements when STM, at the time the order was placed, has expressed reservations regarding the design of the construction.
- 1.12** Products that are damaged by external impacts, such as other building components, including various types of foam, and extreme heat, dampness, chemical and climate impacts etc.
- 1.13** Parts and fittings subject to wear and tear (hinges, locks, locking devices) and weatherstrips that should be replaced due to day-to-day use, application and operation.
- 1.14** The air-tightness of doors delivered with one-point locking systems.
- 1.15** Water entering via the threshold in inward opening doors.

### DOUBLE-GLAZING UNITS

#### The warranty covers the following:

For a period of 10 years from the stamped manufacturing date, the double-glazing unit manufacturer guarantees that double-glazing units delivered for construction purposes will remain free of dust and mist in the interior of the units.

#### The warranty is only valid if:

- The Glass Association Cooperation Organisation's warranty mark and time of manufacture (month and year) appears on the unit's spacer bar.
- The unit has been mounted in accordance with the Glass Association Cooperation Organisation's mounting instructions, cf. GS mounting instruction.
- The unit has not been damaged by external impacts, for example, bumps, impacts, movements in adjacent constructions etc.
- There are no defects caused by frost, other thermal impacts or chemical impacts on the glass, or oxidation due to incorrect storage.
- The unit has not been subject to subsequent treatment upon delivery, for example, sanding, sandblasting, etching, painting, embellishment or other surface treatment.
- The unit has no "attachments" and/or "in-built elements" such as lead panes, alarm systems, window blinds etc. that have resulted in the inside of the unit not being free of dust and mist.
- The sash and frame and installation materials have been subject to the necessary, regular maintenance.

### ELECTRICAL EQUIPMENT

A 1-year warranty is provided for all electrical equipment.



# 10-year warranty

## FOR TIMIUM WINDOWS AND EXTERNAL DOORS

**Warranty and support: STM provides a 10-year warranty on timber/aluminium products. We provide advice on re-treatment and guarantee delivery of spare parts for our products. The extended warranty of 10 years covers all deliveries in the production series TIMIUM 2 + TIMIUM 2020 from the 1st of August 2013.**

### WINDOWS AND DOORS IN TIMBER/ALUMINIUM

**1.1** This warranty is provided by the member of the Association of Danish Window Manufacturers below, hereinafter referred to as the warranty provider. In no way does it restrict or change the rights bestowed upon you under the agreement and/or legislation in relation to your supplier/contractor or in relation to the warranty provider.

**1.2** If, within a period of 10 years from the warranty provider's date of delivery, you have any claims in respect of manufacturing and/or material faults, this warranty guarantees your rights in relation to the warranty provider, as outlined in 1.3. The date of manufacture appears on the product label. If necessary, it is your responsibility to document the time of delivery.

**1.3** If there is a valid claim in respect of manufacturing and/or material faults within the period stated in section 1.2, the warranty provider undertakes to deliver a new product free of charge. However, under this warranty, the warranty provider does not cover any costs for dismantling of the old product and installation of the new product. Likewise, any consequential damage related to the replacement of products is not covered by this warranty. If, at the time of the claim, the product in question is no longer in production, the warranty provider is entitled to deliver another equivalent product instead. If the manufacturing/material fault can be adequately remedied by means of repair/partial replacement, the warranty provider can choose this solution instead. In this case, the repair/partial replacement will be carried out at no cost.

**1.4** This warranty does not cover manufacturing and/or material faults in double-glazing units. However, in these cases, the double glazing manufacturer's warranty, to which reference is made, is applicable.

**1.5** This warranty does not bestow any rights on you other than those outlined in section 1.3.

**1.6** If you wish to make a claim in respect of manufacturing/material faults, the claim must be made within a reasonable time of the fault being discovered or the time at which it should have been discovered. The claim can be lodged with the warranty provider or with the contractor/supplier who delivered the product.

**1.7** This warranty cannot be invoked if the alleged manufacturing/material fault is due to incorrect installation, non-existent or inadequate maintenance or incorrect operation. Reference should be made to the warranty provider's installation, operating and maintenance instructions.

With regard to surface treated timber windows/doors from the factory, your attention is particularly drawn to the maintenance guide and the description "Expected outcome of industrially surface-treated timber elements" (Appendix 14 in The Association of Danish Window Manufacturers' Technical Regulations).

If, exceptionally, you have not received a maintenance/operation guide with your delivery, this can be obtained from the warranty provider.

**1.8** Under this warranty, it is not possible to lodge a claim in respect of manufacturing/material faults that are due to conditions that occurred after the product has been delivered by the warranty provider.

Claims lodged with the warranty provider in respect of faults that can, for example, be attributed to incorrect storage, transportation or installation by a middleman/contractor cannot be invoked with reference with to this warranty.

**1.9** This warranty only applies to products which are physically located in UK when the warranty is invoked.

**We would like to point out that the warranty does not cover:**

**1.10** Plate doors incorporating foam, MDF fillings and lift-slide doors. Here, the DWV 5-year warranty applies as standard

**1.11** Damage and operational problems due to non-existent lubrication and maintenance and washing of the element's external powder-lacquered surface.

**1.12** Damage and operational problems occurring on elements when STM, at the time the order was placed, has expressed reservations regarding the design of the construction.

**1.13** Products that are damaged by external impacts, such as other building components, including various types of foam, and extreme heat, dampness, chemical and climate impacts etc.

**1.14** Parts and fittings subject to wear and tear (hinges, locks, locking devices) and weatherstrips that should be replaced due to day-to-day use, application and operation.

**1.15** The air-tightness of doors delivered with one-point locking systems.

**1.16** Water entering via the threshold in inward opening doors.

### The warranty is only valid if:

- The Glass Association Cooperation Organisation's warranty mark and time of manufacture (month and year) appears on the unit's spacer bar.
- The unit has been mounted in accordance with the Glass Association Cooperation Organisation's mounting instructions, cf. GS mounting instruction.
- The unit has not been damaged by external impacts, for example, bumps, impacts, movements in adjacent constructions etc.
- There are no defects caused by frost, other thermal impacts or chemical impacts on the glass, or oxidation due to incorrect storage.
- The unit has not been subject to subsequent treatment upon delivery, for example, sanding, sandblasting, etching, painting, embellishment or other surface treatment.
- The unit has no "attachments" and/or "in-built elements" such as lead panes, alarm systems, window blinds etc. that have resulted in the inside of the unit not being free of dust and mist.
- The sash and frame and installation materials have been subject to the necessary, regular maintenance.

### ELECTRICAL EQUIPMENT

A 1-year warranty is provided for all electrical equipment.

# The DVV mark

## **The Association of Danish Window Manufacturers**

STM Windows is affiliated to Danish Window Manufacturers and is thus subject to DVV certification.

## **The DVV mark is your guarantee of quality and durability.**

DVV-marked windows and external doors mean that STM Windows is subject to independent factory controls once or twice a year.

Here, controls are carried out on the company's quality management system and to ensure that the elements meet requirements relating to construction, performance, materials and surfaces set out in DVV's Technical Regulations.

Danish Window Certification (DVC) is the independent control body that carries out controls on STM Windows.

## **CE**

### **All STM products are CE marked**

From 1 February 2010, the CE marking of windows and doors is a condition of marketing for products in an EU country. At STM, we naturally comply with the requirements of the legislation.

The DVV mark is associated with the Association of Danish Window Manufacturers' Technical Regulations and signifies:

- that STM Windows has been certified by an independent body
- that STM Windows elements meet the requirements set out in the Technical Regulations
- that STM Windows elements comply with applicable legislation in Denmark
- that STM Windows elements have a valid CE marking
- that STM Windows is affiliated to an appeals board for the handling of complaints
- that STM Windows is affiliated to a 5-year warranty scheme against faults and defects.

Further information can be obtained from the secretariat of the Association of Danish Window Manufacturers.  
+45 72 20 18 22 ([www.vinduesindustrien.dk](http://www.vinduesindustrien.dk))



DANSK VINDUES VERIFIKATION

All elements are tested in accordance with EN 14351-1, which is the applicable standard in relation to CE marking.

Every STM element is supplied with a plaque specifying the properties of the element.



STM WINDOWS A/S  
Kassebølvej 3  
DK-5900 Rudkøbing  
Phone +45 63 51 16 09  
[www.stmwindows.com](http://www.stmwindows.com)

